



Welding Automation

PerformArc® 350S

Small Footprint, High Productivity

- The PA 350S can fit anywhere in your manufacturing plant with a small footprint just under 14' x7'.
- Easy-to-slide teach access doors keep the system slim and allow for tight stacking.
- The Panasonic AC servo positioner turns 180° in under 2.2 seconds, minimizing index time and maximizing productivity.

Easy to Relocate and Set Up

- Moving the PA 350S to a new location within your facility couldn't be easier. Our pre-engineered system with fully-welded frame allows you to simply disconnect the utilities, relocate and reconnect.
- A standard platen design with bolt and dowel holes provides repeatable fixture mounting when multiple fixtures are exchanged on the same work cell.

FILTAIR® Weld Fume Extractor with Automation Hood

- Designed for the rugged demands of robotic industrial welding operations, the FILTAIR Automation solution integrates the FILTAIR Weld Fume Extractor with the Automation Hood, providing a custom-engineered fume extraction solution.



PerformArc® 350S Automation Solution

Dimensional Specifications*		
Frame length	A	4166 mm (164")
Frame width	B	1829 mm (72")
Frame height	C	2286 mm (90")
Platen height from floor	D	786 mm (30.95")
Overall platen size	E	381 mm (15") D 610 mm (24") W
Cell width including doors	F	2052 mm (80.75")
Fixture maximum rotation height	G	1016 mm (40")
Cell front opening (max)	H	1524 mm (60")
Penetration distance (stopping calculation)	I	419 mm (16.5")
Rotation diameter	J	1676 mm (66")
Shipping weight		2041 kg (4500 lb)

*Note: All dimensions are approximate.

Top View

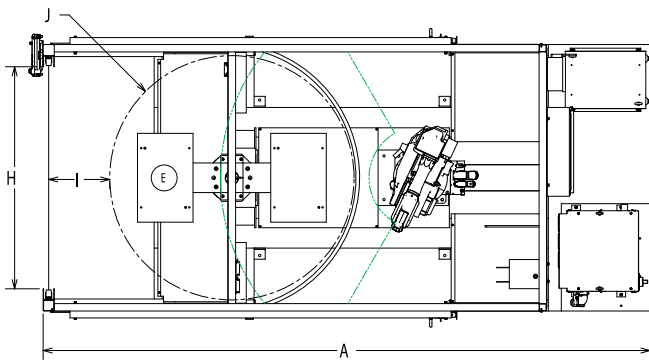

Front View

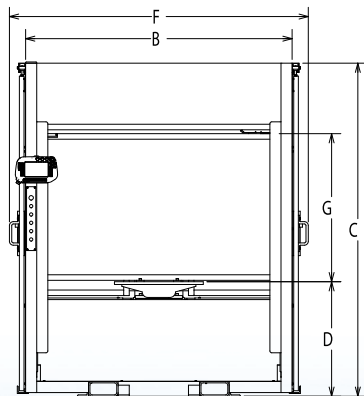

Standard Specifications

Fully Integrated Miller Welding Automation Total Solution Includes:

- Panasonic 6 kg arc welding robot
- Panasonic latest generation 64-bit controller with TFT color display teaching pendant utilizing Windows® CE
- Auto-Access® inverter arc welder
- Miller 4 drive roll wire feeder (dependent on your application)
- Tregaskiss™ 500 A air-cooled welding torch
- High speed main indexing servo positioner 500 kg
- Miller designed and manufactured total productivity system

System features include:

- Integrated operator interface (E-Stop, Auto, Servo On, Mode Select, Table Load/Unload, Start)
- (2) Sliding doors for easy access to the teaching area
- TCP pointer and resident TCP check program
- Tip change monitor and maintenance program door for easy torch upkeep
- Arc start retry, arc overlapping, flying arc start, password protection
- Resume function, shifting functions, online help function

Positioner General Technical Specifications

Model	Servo Positioner
Motor type	1 kW AC Digital Servo
Control type	Servo Control
Payload (per side)	159 kg (350 lb)
Payload offset (from positioner CL)	457 mm (18")
Rotation time (180 deg index)	t < 2.2 sec
Through hole (for utility pass through)	55 mm (2.16")

Robot Options

- TA-1000G3
- TA-1400G3

Welder Options

Auto-Access 300A 60% (Pulse/CV/RMD)	GB2-350A 60% (CV)
Auto-Access 450A 100% (Pulse/CV/RMD)	HM3-350A 60% (Pulse/CV/SPII)
Auto-Access 675A 100% (Pulse/CV/RMD)	HM3-500A 100% (Pulse/CV/SPII)
TAWERS WG 350A 60% (Pulse/CV/SPII)	BP4-300A 40% (GTAW)
TAWERS WGH 450A 100% (Pulse/CV/SPII)	